



Self-propelled fodder mixing wagons

**Primus 600**



## Powerful and comfortable

### – Primus 600

**Fast and structure-protecting picking-up of fodder**  
by means of high performance milling cutter

**Clean picking-up to the kilogramme**  
by means of automatic, load-sensitive lowering of cutter arm

**Smart Feed Cab**  
with Feed Control System



**Individual chassis options**  
depending on operating requirements

**Self-propelled fodder mixing wagons** make the labour-intensive procedure of dairy cattle feeding considerably easier and save time, money and work. Homogeneously mixed ingredients prevent the cows from selecting the fodder.

- + Higher milk yields with improved ingredients.
- + All animals are optimally fed from the physiological point of view and are less prone to diseases.
- + The result are healthy cows and a high degree of cost effectiveness.

**IMS auger**

- low power requirement
- optimised feed structure
- homogeneous mixing

#### Primus 600

**Filling, mixing discharging**  
– carried out with one single vehicle.

Due to the fact that the charging vehicle is no longer required and as a result of the efficient interaction of all components, work is carried out comfortably and in diesel-saving manner. The integrated remote maintenance modem makes the Strautmann self-propelled model an intelligent and reliable overall solution.

- 17 – 22 m<sup>3</sup> of usable mixing capacity
- High-performance milling cutter
- 2 IMS mixing augers
- 2 m of milling width
- A variety of discharge options
- Various chassis options

**Efficient and robust**  
– The pick-up milling cutter



**High-performance milling cutter**

- Picking-up width of 2 m
- Up to 114 knives efficiently pick up the fodder from the silo
- 60 cranked (standard) and 54 straight knives (optional)
- Helical arrangement of knives for maximum picking-up performance with cleanly cut surface
- Change of knives within one minute

**Conical funnel behind the milling cutter**

- Perfect material flow to the centrally positioned elevator
- Significantly less power required than on other designs available on the market
- Increased picking-up performance
- Protection of structure due to the fact that the material directly leaves the milling head

**Elevator**

- Centrally positioned behind the milling cutter for fast, structure-protecting material flow
- Smoothly running, low-maintenance elevator conveyor made of rubber
- Hydraulically powered
- Infinitely variable speed adjustment
- Reversible for exact picking-up of ingredients



**Fodder picking-up & transport**

- Neat picking-up right to the ground
- Additionally adjustable supporting rollers made of solid material to the right and left of the picking-up head for a stable and safe position
- Elevator conveyor with robust lug tread for neat fodder flow
- No connection of rubber belt and side panel due to wear resistant plastic sealing
- Optimum trajectory from elevator into mixing container
- Load-sensitive operation of automatic lowering of cutter arm for extremely structure-protecting picking-up of fodder and simultaneous maximum picking-up performance
- Suspension due to hydraulic storage of nitrogen for utmost driving comfort



**Mineral fodder feeding flap**

- Optional equipment on the elevator arm
- Activation of elevator conveyor directly from the cabin
- For comfortable addition of smaller quantities of fodder and fodder additives
- Direct distribution of the additional components in the whole container
- Fast and homogeneous mixing

## The allround talent

### – IMS (Intensive Mix System) mixing auger

#### The IMS mixing auger –Variability and strength for any purpose

Due to the patented knife adjustment system, the IMS mixing auger can be perfectly adapted to your specific conditions of use. The robust and low-maintenance angular gear ensures long service life even under challenging conditions.

Strautmann Verti-Mix fodder mixing wagons substantially contribute to increase the productivity of modern dairy farms. The perfect geometry of container and IMS mixing auger is supported by the newly developed mixing auger in stepped flight design with 60-degree elements. This ensures:

- Low power requirement
- Preservation of fodder structure
- Homogeneous mixing
- Energy-saving short mixing times

Excellent mixing quality and proven easy towing guarantee absolute cost-effectiveness for any kind of application.



#### Adjustable front auger end/scrapper

Due to adjustable scraper bars at the front auger end and at the scrapper, even finest components are reliably picked up from the ground and homogeneously mixed.

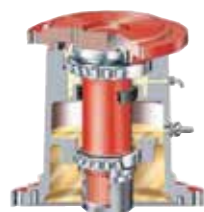

#### Robust heart

The heart of the IMS mixing auger is the very robust and durable gearbox. Stability and long maintenance intervals are achieved by means of a large-sized pair of tapered rollers, double sealing and a large grease chamber.

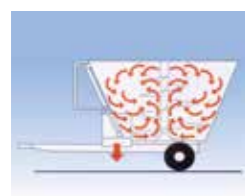

#### Effective mixing

The perfect harmonisation of mixing auger geometry and the distance to the container wall forms the basis for quick and homogeneous mixing.

## Extend service life – Save money!

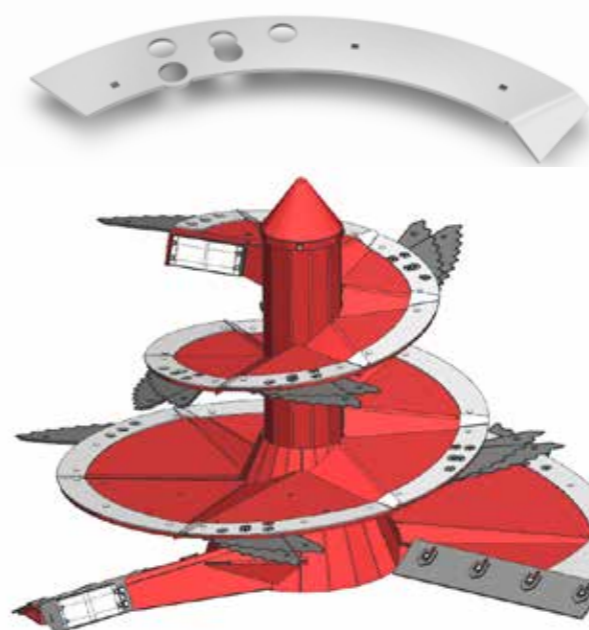

#### Innodur

Optional „INNODUR“ wearing elements significantly extend the service life of the IMS mixing auger.

- 5 mm thick and 100 mm wide stainless steel elements
- Screwed to the auger windings with an overlap
- Quick and easy subsequent mounting also possible
- No labour-intensive welding required

### For high demands – Heavy-duty design

When the mixing auger is replaced with a residual thickness of 5 mm:

Standard mixing auger 15 mm

- Wear material 10 mm

Heavy-duty mixing auger 20 mm

- Wear material 15 mm

→ 50% longer service life = 50 % less wear costs

#### Stainless steel lining

Fodder rations with a high maize percentage (>75 % of the dry substance content of the total ration), in particular have an increased percentage of aggressive lactic acid. The acid attacks the container material and promotes the formation of rust films. A stainless steel lining for the container effectively prevents this.

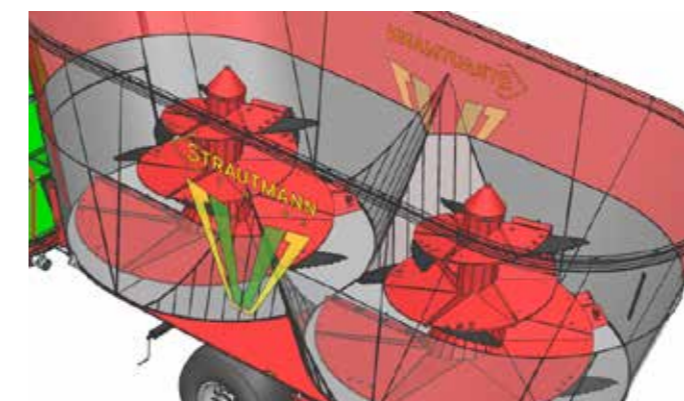

- Stainless steel elements
- 1.5 mm thick and 90 cm high side panel elements
- 3 mm thick bottom plate
- Also subsequently available with 3 mm thick side panel elements

# Individually equipped for your needs

Special equipment options help you to adapt your IMS mixing auger even better to your individual needs:

- Standard short knives
- Optional long knives, ideal for loosening straw and baled silage



## More safety for your animals!

Protective cover between mixing auger and coaxial gearbox

- Made of robust plastic
- Recommended for compact mixtures (compact TMR) or for addition of larger quantities of water
- Reliable protection against fodder deposits between mixing auger and gearbox

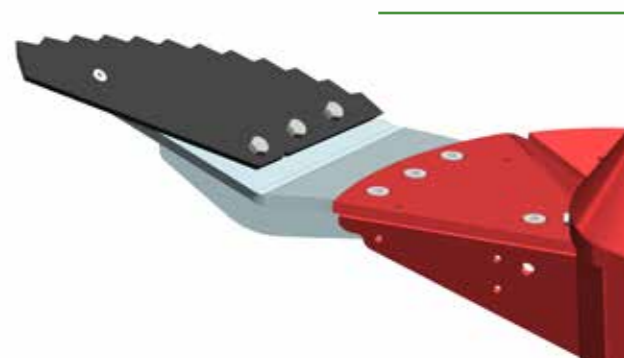

**Bale knife**  
The bale knife is perfectly suitable for undoing round bales.

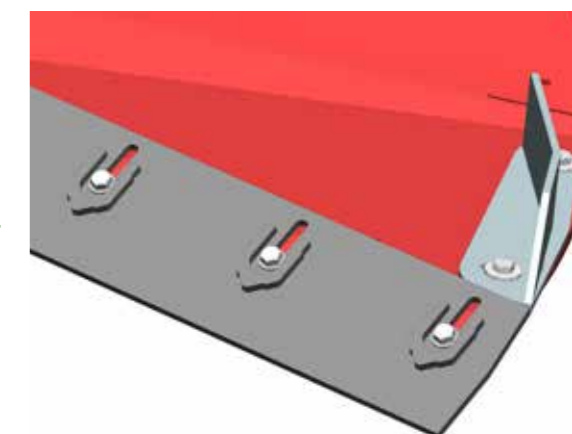

**Scraper**  
"Scrapers" especially developed for very poorly structured feed rations (compact TMR) ensure an additional mixing effect and an improved fodder movement.

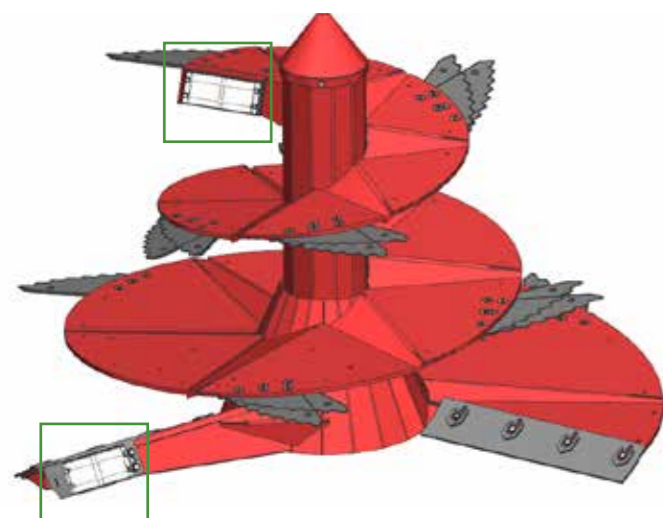

**Magnetic system**  
Each silage and any kind of purchased fodder might contain metallic foreign objects which might harm your dairy cattle. The Strautmann magnetic system (optional) mounted directly at the mixing auger protects your valuable livestock against internal injuries, thus ensuring herd health.

The industrial magnets are mounted such that they have direct and immediate contact with the mixed fodder and thus very effectively filter out metallic foreign objects without them being carried away again from the magnet by the following fodder.



Result after 14 days of using our magnets (wedding ring as reference in the bottom right of the photo)

## Comfortable and spacious – Smart Feed Cab



### Cabin

- Safety glazing on 3 sides with heated front screen for optimum view
- Lightly tinted skylight, additional protection from sunlight
- Comfortable seating capacity with leg space
- Low-noise working in the cabin

### Access door

- Wide access over almost the entire cabin length
- Comfortable entry and exit

### Optimum view

- Optimum view even in case of great picking-up heights
- Double windscreen wiper
- Heated and electrically adjustable outside mirrors

## Working in the comfort zone – Made for you



### Driver seat

- Air-suspended
- Sufficient leg space
- Setting functions for driver seat and armrest for individual workplace adjustment



### Armrest

- Swings along for maximum comfort
- Room for all controls
- **Multi-function joystick and keypad:** Functions can be personalised for each user and depending on the operating mode (travel, feed and discharge) –and unloading).

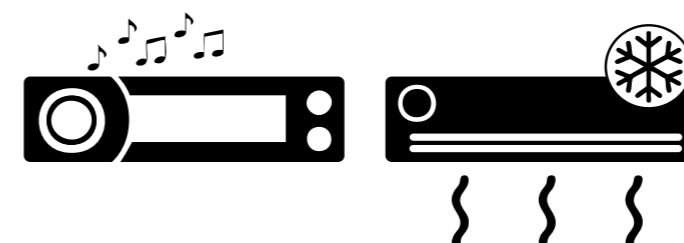

### Radio & Air Conditioning

- Air conditioning as standard
- DAB+ radio with hands-free system

# Safety and comfort

## - with Strautmann Feed Control

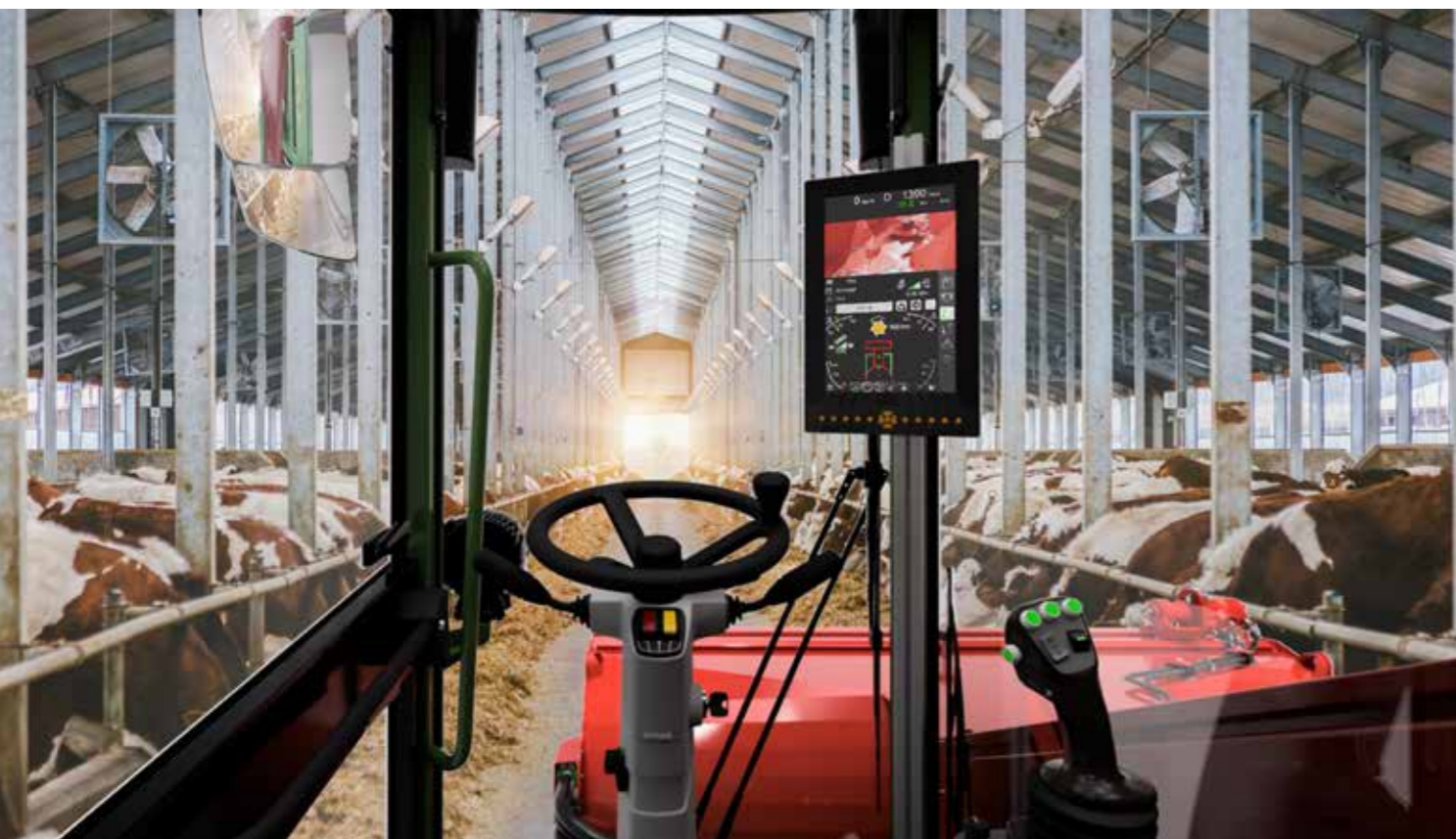

### Feed Control

- Space saving & clearly organised
- 3 displays in 1
- Free assignment of individual functions
- 12" touch screen, highly scratch resistant and reliable

### Weighing system

- Programmable weighing system as standard
- Data transfer via Strautmann Data System (SDS) on page 15

### Mixer drive

- Hydrostatic with 2 speed levels
- Each speed can be controlled proportionally

### Travel drive

- Hydrostatic with stepless speed adjustment
- Automatic travel mode: 0-25 or 0-40 km/h
- Milling mode: 0-7 km/h
- Spreading mode: 0-15 km/h



### Picking-up mode

- Weighing device
- Camera (rear-view and container camera)
- Milling pressure
- Pick-up arm lowering, manual & automatic
- Elevator conveyor, sense of rotation
- Mixing auger speed

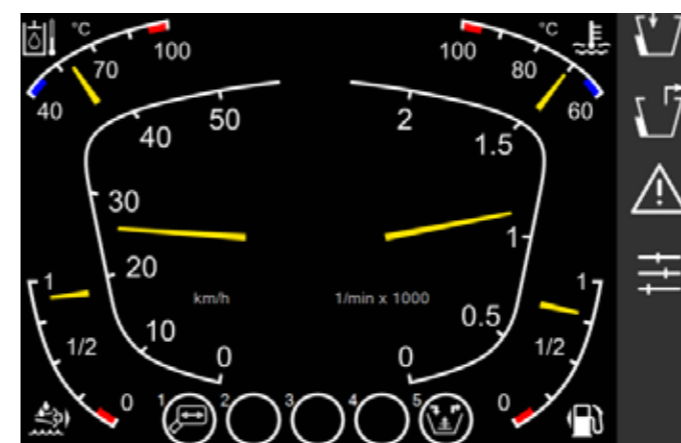

### Travelling mode

- Weighing device
- Camera (rear-view and container camera)
- Speed
- Engine speed

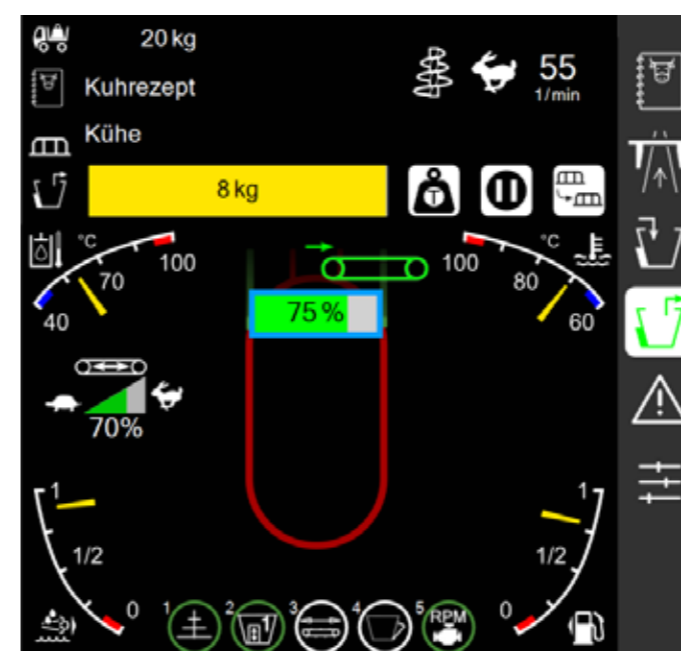

### Discharge mode

- Weighing device
- Camera (rear-view and container camera)
- Gate display
- Crossover conveyor display
- Crossover conveyor sense of rotation
- Crossover conveyor speed
- Mixer speed



## Keeping an eye on feeding at all times – Strautmann Data System (SDS)

The Strautmann Data System (SDS) is a new platform for all data streams generated on, with or by the machines. An elementary SDS module for the self-propelled fodder mixing wagons is the feeding software. SDS enables programming recipes and defining discharge points. The clearly organised component and recipe management can be maintained on the PC or mobile end devices. One or more users or operators can access the created recipes and perform the feeding process according to specifications. Access to the information is possible for several users who can carry out mixing and feeding according to exact specifications. The Primus records all important machine and weight data and synchronises them back to the system. Thus, feeding can be easily analysed, assessed and then adjusted accordingly. A valuable tool for optimising the feeding process and promoting performance and animal health with simultaneous minimum consumption of resources.



A special highlight for contractor-based feeding and businesses with several locations is the premium variant: This option enables the creation, management and separate analysis of several businesses and more recipes. It comprises the comparison of target and actual figures as well as the working time recording for each employee and each business for a clean documentation and invoicing. In future, SDS is to be further expanded in terms of its capabilities to support e.g. service and maintenance intervals or to generate more transparency for the customer in terms of warehouse management.

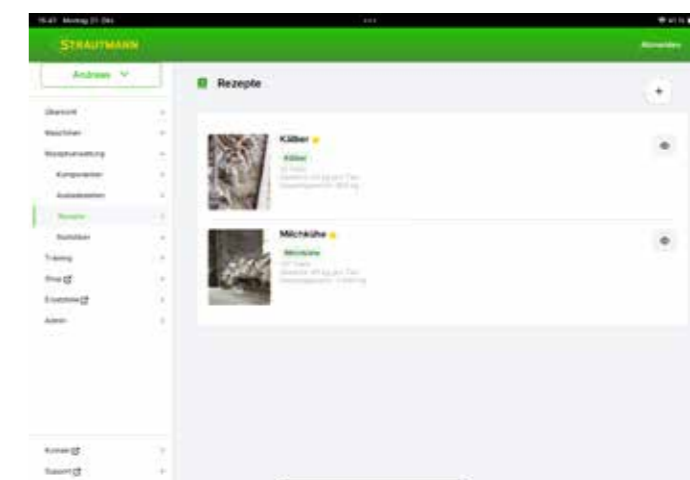
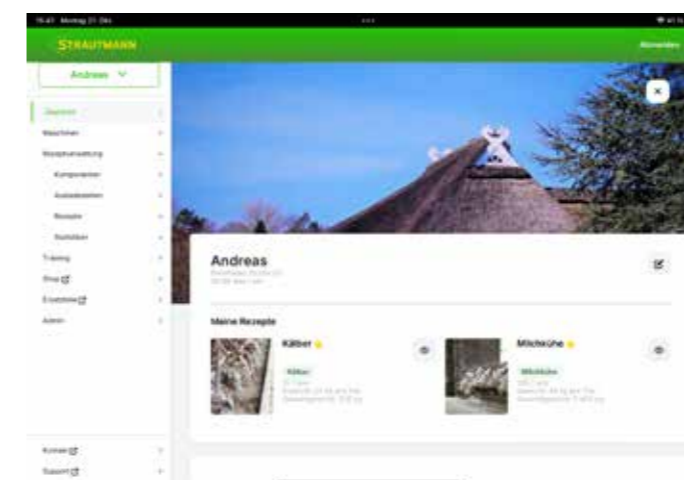



# For road and farm – Chassis



### Chassi

- Welded frame made of high-grade steel with front axle oscillating support for maximum stability
- Maximum driving comfort due to parabolic suspension of the entire vehicle
- Oil-hydraulic drum brake, 4-wheel braking for maximum safety

### Traction drive

- Standard automotive travelling mode and engine speed reduction when maximum speed is reached for reduced fuel consumption
- Optional 4-wheel drive for difficult terrain and increased climbing ability even under load



### Leaf suspension

- Mechanical leaf suspension as standard
- Low-maintenance and robust



### Air suspension

- Optional for more comfort
- Chassis can be lowered
- Increased driving comfort, especially in inter-farm use or difficult farmyard conditions



### 4-wheel steering

- Compact and manoeuvrable machine even for narrow stable conditions
- A comfortable solution on the farm to minimise the turning radius
- In combination with the tail swing suppression good overview even in narrow lanes and stables

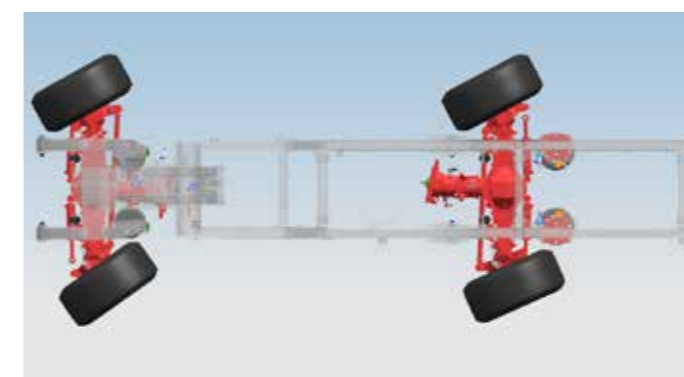

### Crab steering

- Comfort function for safely approaching the silo wall
- Full concentration on fodder picking-up at the silo stack possible
- Furthermore, the axles can be also steered manually
- by means of the terminal to enable safe manoeuvring out of corners

## More safety

- due to tail swing suppression

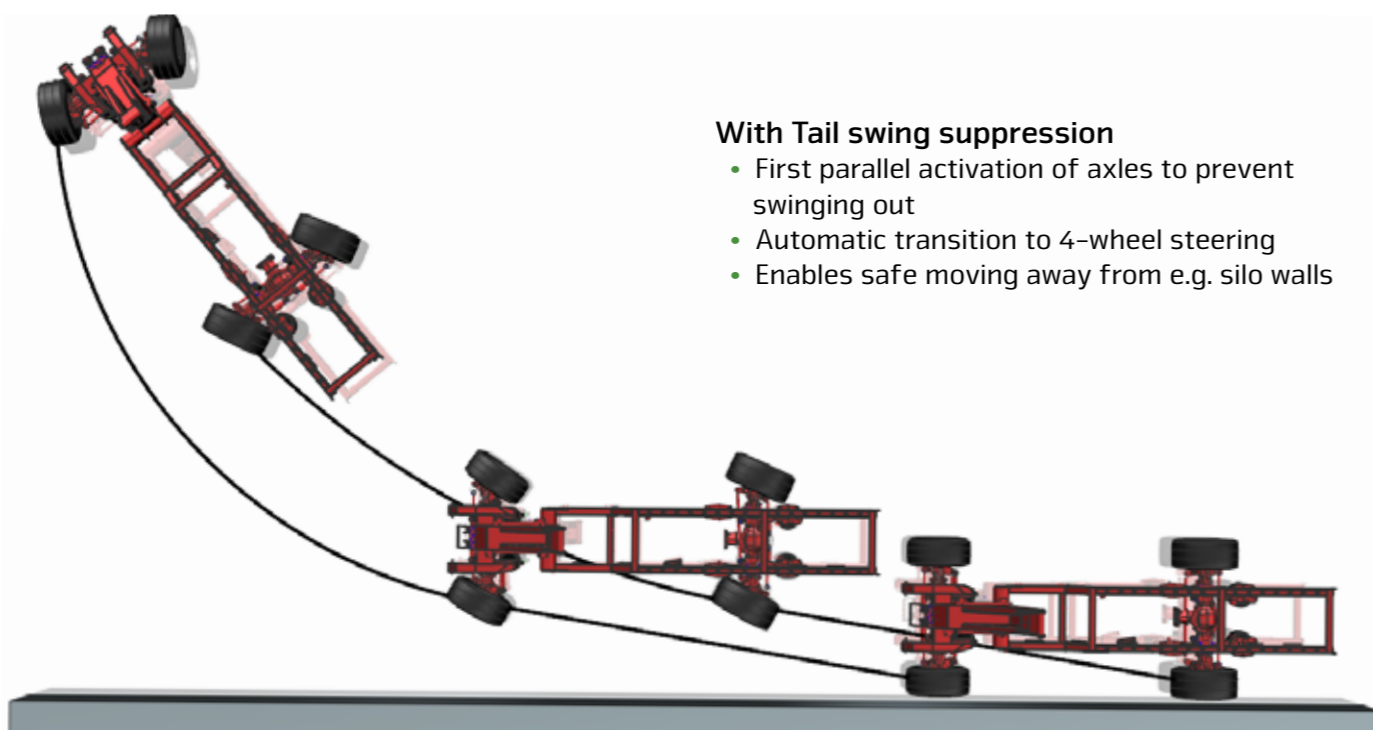

### With Tail swing suppression

- First parallel activation of axles to prevent swinging out
- Automatic transition to 4-wheel steering
- Enables safe moving away from e.g. silo walls

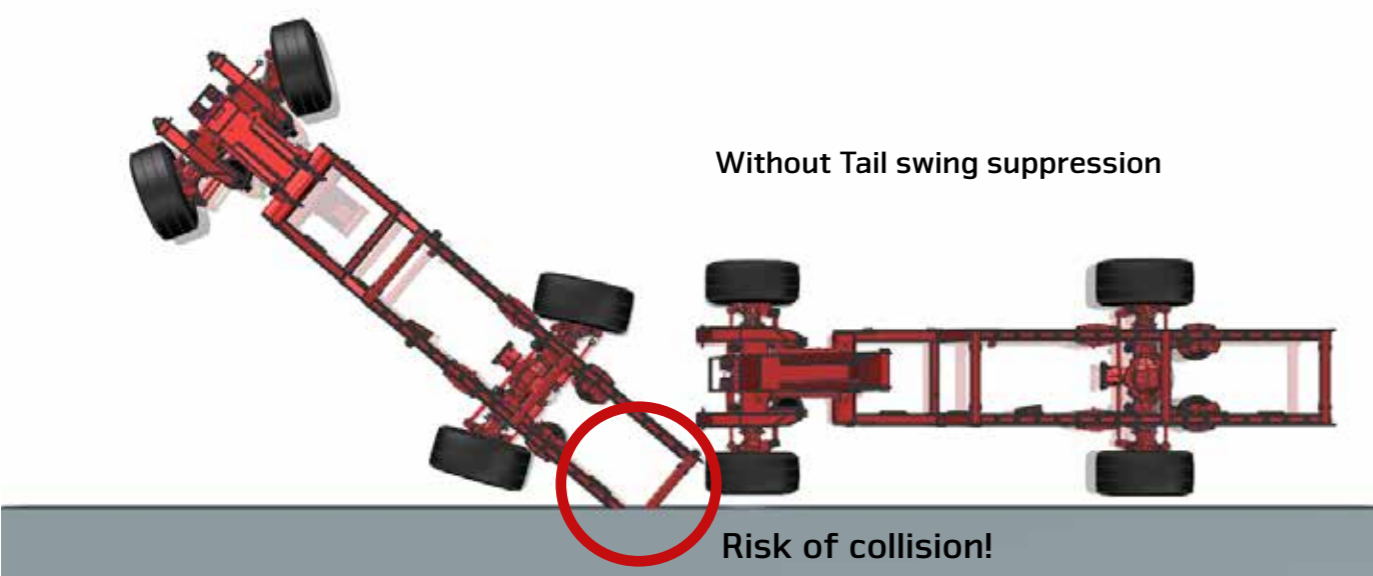

### Without Tail swing suppression

Risk of collision!



### 6-cylinder engine

- Engine position at the right-hand front
- Powerful and economical emission-standard-V-engine
- Turbo-diesel engine with water cooling
- Easy maintenance and care of engine and hydraulic
- power train due to good accessibility from all sides
- 165 kW/225 HP
- Use of HVO fuel possible

## Technical data

	Primus 617	Primus 620
<b>Dimensions</b>		
Width with crossover conveyor [m]	2.34	2.34
Front outside wheel width [m]	2.34	2.34
Width with two discharge doors	2.46	2.46
Length with front crossover conveyor [m]	9.67	9.74
Length with rear crossover conveyor [m]	9.78	9.78
Elevator width [m]	0.58	0.58
Milling cutter diameter [m]	0.61	0.61
Picking-up width [m]	2.00	2.00
Max. picking-up height [m]	5.50	5.50
Distance between bottom plate and floor [m]	1.02	1.02
<b>Dead weight</b>		
Basic machine from [kg]	14,700	15,000
<b>Loading capacity</b>		
Usable mixing capacity [m <sup>3</sup> ]	17.0	20.0
Usable mixing capacity with extension [m <sup>3</sup> ]	19.0	22.0
<b>Axle</b>		
Wheelbase [mm]	3.97	3.97
<b>Vehicle height depending on tyres</b>		
435/50 R 19,5 [m]	2.74	-
455/45 R 22,5 [m]	2.78	3.04



[www.strautmann.com](http://www.strautmann.com)

B. Strautmann & Söhne GmbH u. Co. KG



Bielefelder Straße 53  
D-49196 Bad Laer  
Phone: +49(0)5424/802-0  
[info@strautmann.com](mailto:info@strautmann.com)  
[www.strautmann.com](http://www.strautmann.com)