

STRAUTMANN



Multi-purpose forage wagon

Zelon



Outstanding ease of towing with short cutting length

- The Zelon



Powerful spiral rotor
with welded-on tine plates for optimum protection of fodder and maximum cutting quality

Varied superstructure options
the right choice for any application

Efficient loading
by means of the unique Continuous-Flow System

Exact cutting
by means of the 37-knife Exact-Cut cutting unit

Various chassis options
for different requirements

Zelon

The Zelon represents the stepping stone into the silage wagon technology from a loading capacity of only 24 m³. The machine offers even smaller family-owned businesses the chance to benefit from the advantages of a powerful silage wagon for green fodder harvesting based on own machinery. Whether in daily fresh grass feeding or for use in silage: This wagon guarantees optimum work results and impressive performance.

- Easy-towing and powerful silage wagon for smaller and medium-sized family-owned businesses
- 3 models with a loading capacity of 24, 28 and 35 m³
- Compact design
- Various superstructure options available for flexible use

Contents

Continuous-Flow-System	4-5
Drive & rotor	6-7
Exact-Cut cutting unit	8-9
Silage superstructure	10-11
Transport floor & unload	12-13
Folding grille superstructure	14
Fresh grass feeding	15
Chassis	16-17
Operation	18
Technical data	19

The system for efficient charging – The Continuous-Flow-System

Due to the interaction of different components, the Continuous-Flow system ensures excellent loading performance with little power required.

Pick-up, guide roller, rotor and Exact-Cut cutting unit are ideally matched and complement each other perfectly. This results not only in excellent cutting quality but also in easy towing, thus saving power, money and time.

Cutting unit & rotor:

Exact cutting due to perfect interaction

- Tine plates welded on the rotor ensure uniform and precise scissor-type cut
- The small distance between rotor tines and knives ensures an exact cut with little power required

Pick-up: Gentle picking-up of grass and dispersal of swathe

- Low-wear, camless pick-up
- Plastic strippers
- 1.80 m in width
- 6 tine rows placed in V-shape disperse the grass
- Due to the additional guide roller, the pick-up is in a very flat position
- Optimum adaptation to the ground
- Guide wheels at the pick-up ensure flexible adaptation to the ground

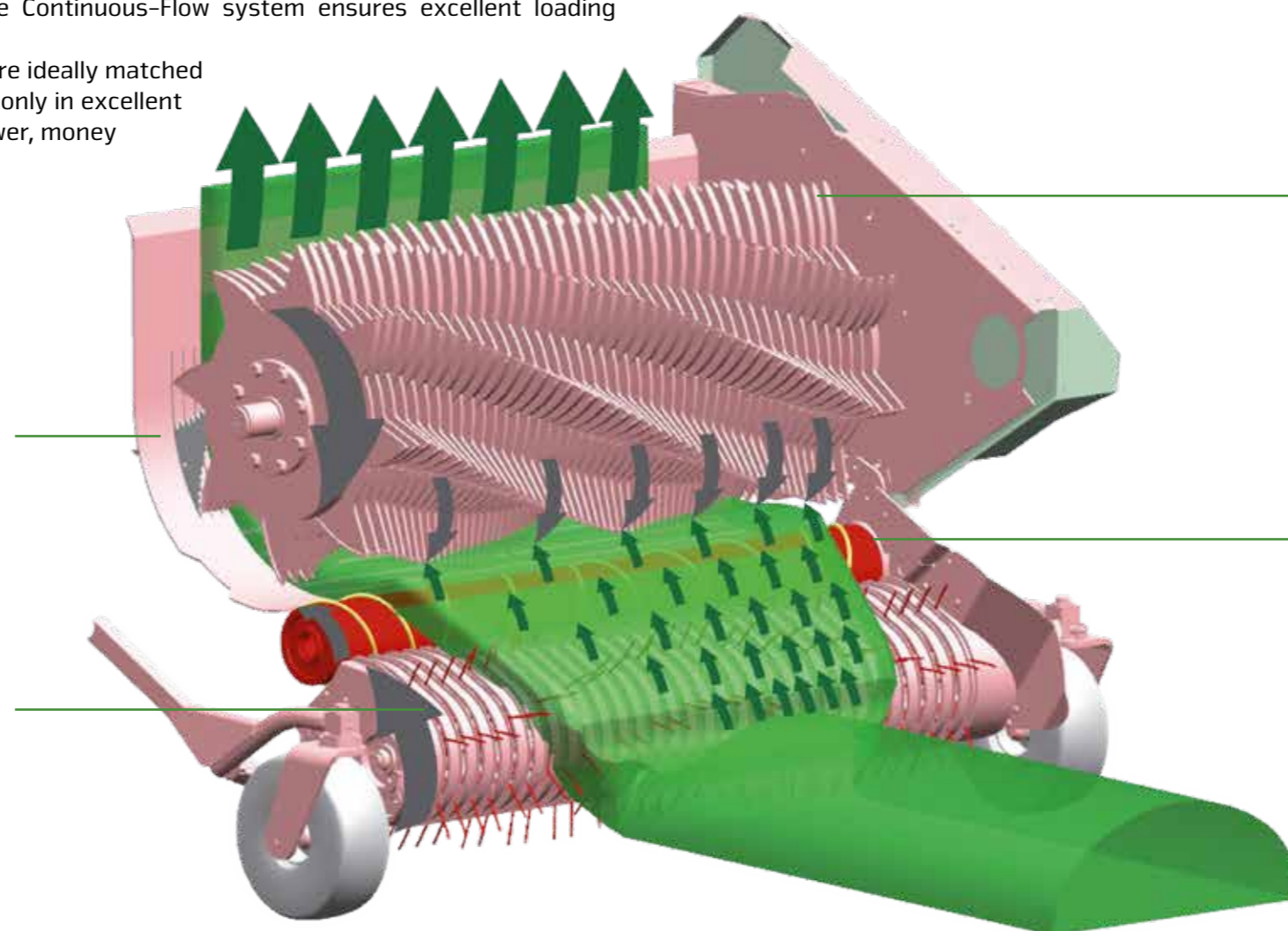

Optimum filling degree over the entire width

- Reduced power requirement due to higher positioned rotor and thus shortened conveyor duct
- The material is conveyed into the cargo space over its entire width
- Maximum and homogeneous filling degree = more weight per m³

Dispersal and acceleration of crops

- Quicker charging with less power required
- The guide roller disperses the loaded material by means of the special welded-on layer
- Thus, the loaded material is homogeneously conveyed to the rotor over the entire width
- Acceleration of material ensures homogeneous flow of material without any hesitation
- Always homogeneous delivery of loaded material from pick-up to rotor
- No fodder piling up

FLEX-LOAD PICK-UP

Flexible loading – Saving time and effort

- Optional
- Flexible plastic tines made of special PUR composition
- 6 helically arranged tine-segment rows
- Tines are horizontally flexible, vertically rigid to ensure safe picking-up
- Ideal adaptation to the ground
- Penetration into the ground is prevented, thus avoiding contamination of fodder
- Minimum wear and hardly any tine breakage
- Change of tines within one minute with only one tool required

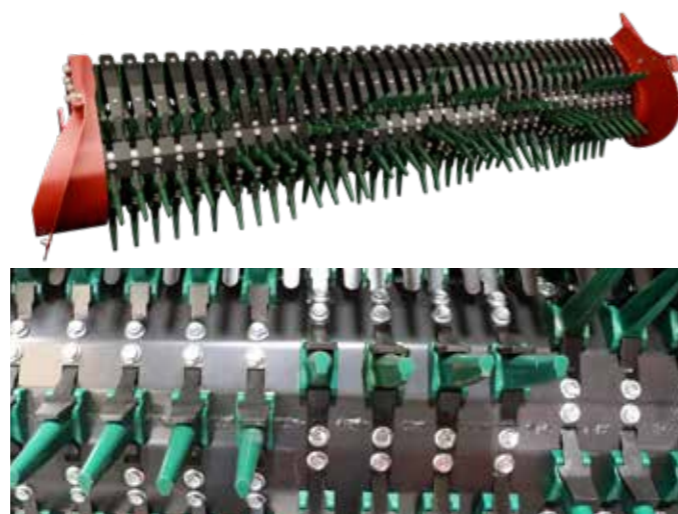

Technical modifications reserved



Technical modifications reserved

Easy towing, efficient and powerful

- The power train



The conveying unit of the Zelon is powered via a 1¼" thick Duplex chain on the left-hand rotor side. The automatic chain tensioner installed as standard and an automatic chain lubrication system reduce maintenance to a minimum, which increases efficiency and extends the service life of the individual components.

Robust and strong

- 1650 Nm high torque protection by means of cam-type cut-out clutch in front of the main gearbox protects the power train against overload
- Low power required from 95 hp of tractor output



Durable and robust

- The feeder rotor

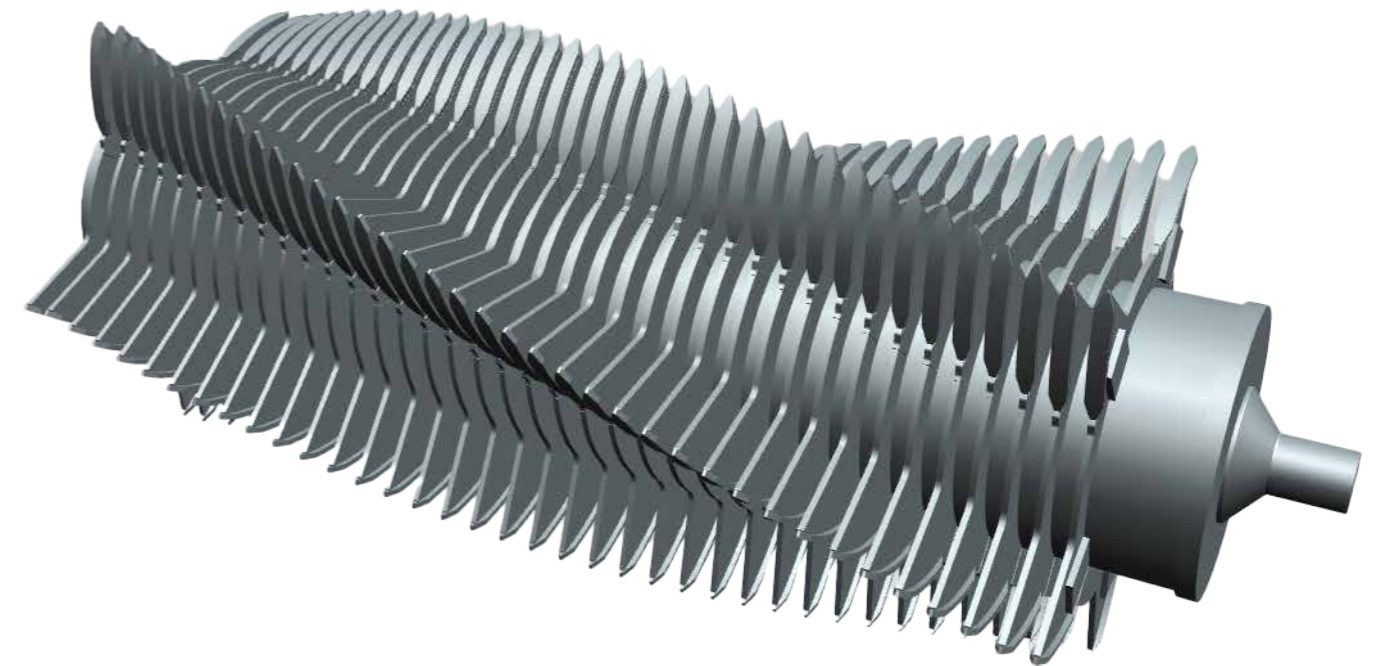

Due to its large conveying width of 1500 mm and a diameter of 725 mm, the feeder rotor of the Zelon has a high throughput rate. The 8 mm wide conveying tines are helically arranged on 5 tine rows and continuously welded to the rotor tube, making the rotor extremely robust, durable and smooth-running.



Wide tine plates

Due to the small distance to the knife, the 21 mm wide tine plates made of Hardox ensure permanent precise scissor-type cut.



Wide rotor strippers made of Hardox

Thanks to the intelligent stripper contour, the conveying tine always retracts from the material flow at an angle of more than 90°. The 14 mm wide strippers prevent the material from becoming "mushy" and at the same time enable high compaction in the cargo space, which saves energy and protects the fodder structure.

Consistently outstanding cutting quality

– The Exact-Cut cutting unit



Exact-Cut cutting unit

- Standard equipment with 37 knives with two blades each for double the service life
- 39 mm theoretical cutting length
- Almost maintenance-free design reduces maintenance costs
- Central knife-locking mechanism enables quick knife change
- Automatic wayback ensures high driving comfort and consistent cutting quality

Knife change made easy



Easy knife change

- Enclosed extraction lever for easy and quick removal:
 - Lever is inserted in the knife protection system
 - With light pressure to the front, the knife slips off the locking shaft



Knife protection system with spot-on triggering

The proven knife protection system in Strautmann forage wagons is equipped with a spot-on triggering function and is particularly low-maintenance. The knife is completely retracted from the conveyor duct in case of contact with a foreign object, thus minimising damage to the knife blades.

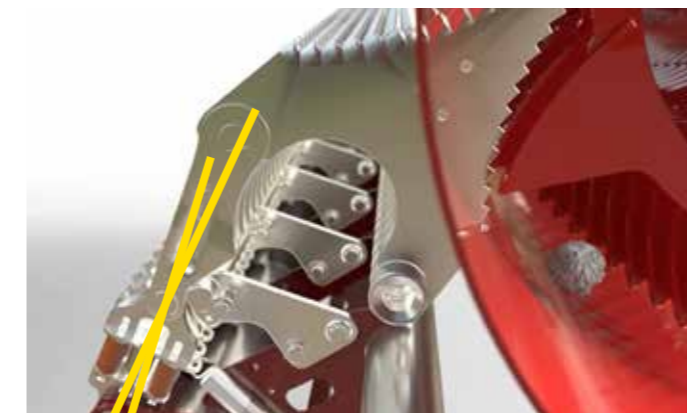

Knives in conveyor duct

- Knife protection system fallen under dead point
- Knives are held in the duct

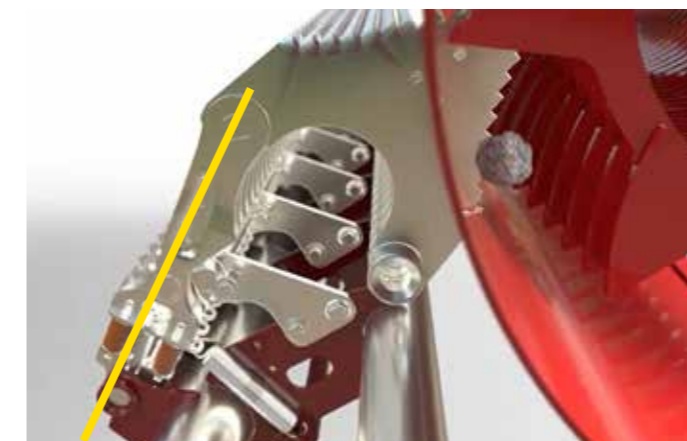

In case of contact with a foreign object

- Rubber dampers are compressed
- Knife protection system reaches dead point
- Spring for the wayback mechanism is tensioned



Actuation of protection system

- Knife protection system has passed dead point
- Knife retracts completely
- Spring for the wayback mechanism is tensioned at its maximum

Automatic wayback

When the counter-force of the foreign object decreases or does no longer exist, the spring automatically retracts the knife into the conveyor duct

Silage superstructure

Robust and combinable



Silage superstructure



- Robust all-steel superstructure**
- Perfect securing of loaded material by means of height-adjustable superstructure brackets and ropes
 - Use in forage harvesting is possible with the ropes removed



- Practical harvesting plate**
- Inward-folding front grating upper part
 - Low loading height for easy chopping and loading from the front



- Optimum filling degree**
- Load-protection bars prevent the fodder from overflowing
 - Optional automatic loading system
 - Presetting of filling degree possible
 - When the loaded material presses against the feelers of the automatic loading system, the transport floor starts to run



- Sturdy tailgate**
- Wide opening option for quick unloading
 - With integrated pressure switch for the level indicator (on wagons without dosing unit)



Silage superstructure

Quick and uniform discharge

Transport floor & discharge



Effective beaters

- Dosing unit with 3 beaters as standard
- Equipped with aggressive ripping tines
- When the wagon is full, the bottom beater is able to evade to the rear thus stopping the transport floor feed via a sensor
- Powerful drive via large-sized roller chains



2-stage switching for transport floor

- Hydraulic drive by means of one-sided feed gearing with powerful oil motor
- Optional 2-stage switching ensures maximum transport speed and fast unloading



Durable platform

- Completely welded steel floor
- ACC priming and powder coating of entire superstructure ensure perfect corrosion protection



Strong transport floor

- Embedded round steel chains of 10x31 mm and a breaking load of 13 t
- Handy, screwed U-shaped profile strips



Transport floor & discharge

Folding grille superstructure

- The compact one



Perfect for low overhead clearances

- Hydraulically folding grille
- Reduction of overall height by up to 80 cm (70 cm with dosing unit)
- Easy passing through stables



Dosing unit

- 2 beaters unloading a homogeneous swathe onto the silo
- Even material transfer onto the crossover conveyor

Fresh grass feeding

- Reduce costs - Increase milk yield!



Robust crossover conveyor

- Neat and homogeneous fodder unloading
- ISOBUS control as standard
- Enables maximum passage and trouble-free unloading



Easy handling

- Parking position beneath the platform
- Easy sliding-in of conveyor belt when not in use
- When using the crossover conveyor, the tailgate is fixed to the crossover conveyor and automatically blocked



Reliable picking-up of material

- Safe intake of mower swathe by 1.80 m wide pick-up
- Maximum protection of fodder due to Continuous-Flow system

Safety & comfort

- On the field and on the road

Different chassis options

ensure optimum driving comfort and safety at any time:

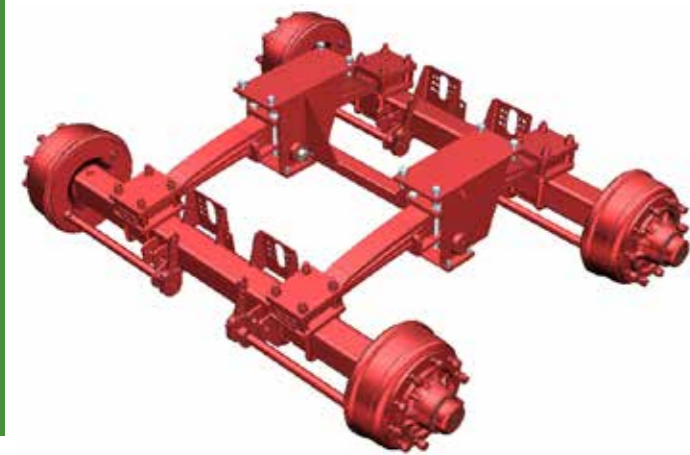

Boogie tandem chassis

- Chassis with parabolic suspension for an admissible axle load of 13 t, standard equipment
- Maximum tyre size 650/40 R 22.5
- Brake 400 x 80 mm
- Optional 16-t chassis
- Maximum tyre size 710/40 R 22.5
- Brake 400 x 120 mm



Top linkage

- Standard equipment
- Admissible tongue load 2 t



Optional bottom linkage

- Bottom linkage with coupling head or drawbar lug
- Admissible tongue load 3 t



Passive steering axle

- Optional for 13-t chassis
- Standard equipment with 16-t chassis
- Excessive friction of the wheels on the ground is prevented
- Protection of sward
- Optional detection of travel direction for automatic locking of steering axle when reversing



Aim high the easy way

- Hydraulic folding drawbar as standard
- With double-acting cylinders
- For comfortable and easy travelling over the silo
- Optional with hydro-pneumatic drawbar suspension



Optimum adaptation to the ground

- Guide wheels at the pick-up ensure flexible adaptation to the ground
- Easy and quick adjustment of rake depth by means of hole pattern at the pick-up guide wheels
- Optional additional sensing roller behind the pick-up for exact working even on soft or wet ground



Additional sensing roller

The 500 mm wide additional sensing roller ensures optimum adaptation to the ground. It prevents ground contact of the pick-up tines in humid harvesting conditions and hilly terrain

Operation

Several operating options enable an adapted and easy operation

E-CONTROL SET



- Standard equipment
- Operation of hydraulic functions via toggle switch
- Comfortable & easy
- Oil supply via load-sensing

ISOBUS CONTROL

The Strautmann ISOBUS control helps you to have all machine functions under control at any time. The particularly intuitive operator panel of the software is divided into loading and unloading mode and road travel mode. The keys are arranged ergonomically and ensure comfortable and safe operation of the machine functions. Numerous automatic functions such as e.g. automatic charging, automatic drawbar system and automatic reverse system ensure intuitive and comfortable machine operation.



Due to the compatibility of the Strautmann ISOBUS control, most varied terminals can be used for the Strautmann forage wagons. Thus, depending on the tractor type, all machine functions can also be operated via the tractor joystick.

STRAUTMANN "SMART 570"



- Optional right-hand terminal
- 5.7" coloured screen
- Optimum control of the loading and unloading process and safe road travel

Technical data

	Zelon 250	Zelon 290 without / with DO	Zelon 360 without / with DO
Dimensions			
Length [m]	7.79	8.59 / 9.33	9.99 / 10.73
Outside wheel width 13-t chassis 620/40 R 22.5 tyres [m]		2.71	
Outside wheel width 16-t chassis 710/40 R 22.5 tyres [m]		2.80	
Height with silage superstructure 620/40 R 22.5 tyres [m]		3.65	
Height with silage superstructure 710/40 R 22.5 tyres [m]		3.75	
Change height with folding grille folded up [m]		+0.04	
Change height with folding grille folded down (without DO) [m]		-0.79	
Change height with folding grille folded down (with DO) [m]		-0.69	
Cargo space dimensions			
Height [m]		2.22	
Width [m]		2.10	
Length [m]	5.28	6.08	7.48
Loading capacity DIN [m ³]	24	28	35
Loading capacity, medium compaction [m ³]	44	51	65
Dead weight			
Dead weight, standard equipment [kg]	5,600	5,900/6,500	7,000/7,600
Gross vehicle weight rating			
Gross vehicle weight rating, standard equipment [kg]		15,000	
Gross vehicle weight rating, optional equipment [kg]		19,000	
Power required			
Power required from [kW/HP]	70 / 95	77 / 105	88 / 120
Additional data			
Conveying unit type		Rotor	
Number of knives [pcs.]		37	
Picking-up width of pick-up [m]		1.80	
Theoretical cutting length [mm]		39	

Figures, technical data and weights may change due to technical development and are not binding for delivery.





www.strautmann.com

B. Strautmann & Söhne GmbH u. Co. KG



Bielefelder Straße 53
D-49196 Bad Laer
Tel.: +49(0)5424/802-0
info@strautmann.com
www.strautmann.com