



straumann



herpa

Sherpa



The Sherpa

– Start off into the world of self-propelled fodder mixing technology



Milling head
Efficient cutting and collection of fodder

Elevator
at the centre of the picking-up head for optimum fodder transport and maximum performance

Compact dimensions
with low height and width

Vario² mixing auger
for homogeneous mixing results

The Strautmann Sherpa – The start-off model

- Particularly easy to manoeuvre
- Low overall height
- Easy operation
- The perfect model to start off with

Pick-up milling cutter

- Standard equipment
- Maximum efficiency
- Quick and clean picking-up

The new generation of Strautmann self-propelled fodder mixing wagons makes the labour-intensive dairy cattle feeding procedure much easier thus saving time, money and labour. Due to homogeneously mixed components, the cows can no longer select the fodder
→ Higher milk yield with improved ingredients

All animals are optimally fed from the physiological point of view and less prone to diseases which lead to healthy cows and a high degree of profitability.

Contents

The picking-up system	4-5
Vario² mixing auger	6-7
Safety & comfort	8
Travel & mix	9
Performance & operation	10
Technical data	11

Fast & efficient
 – The pick-up milling cutter

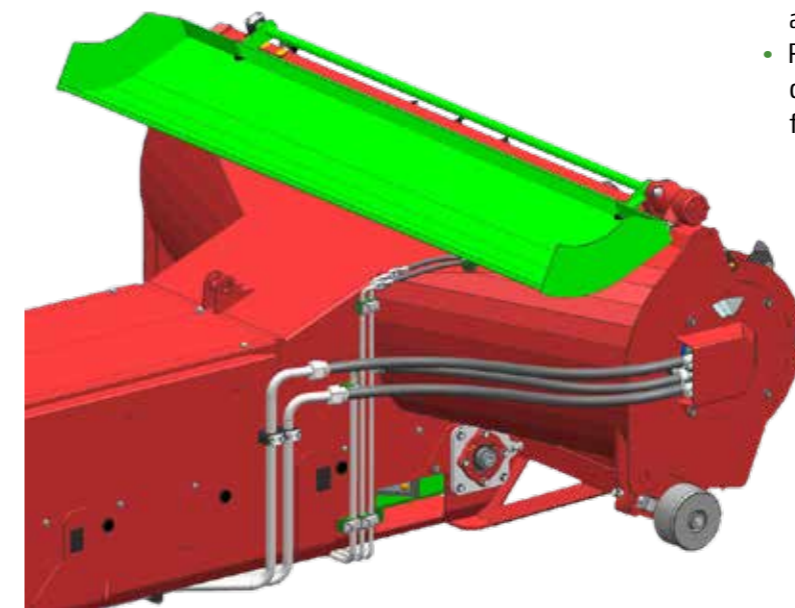
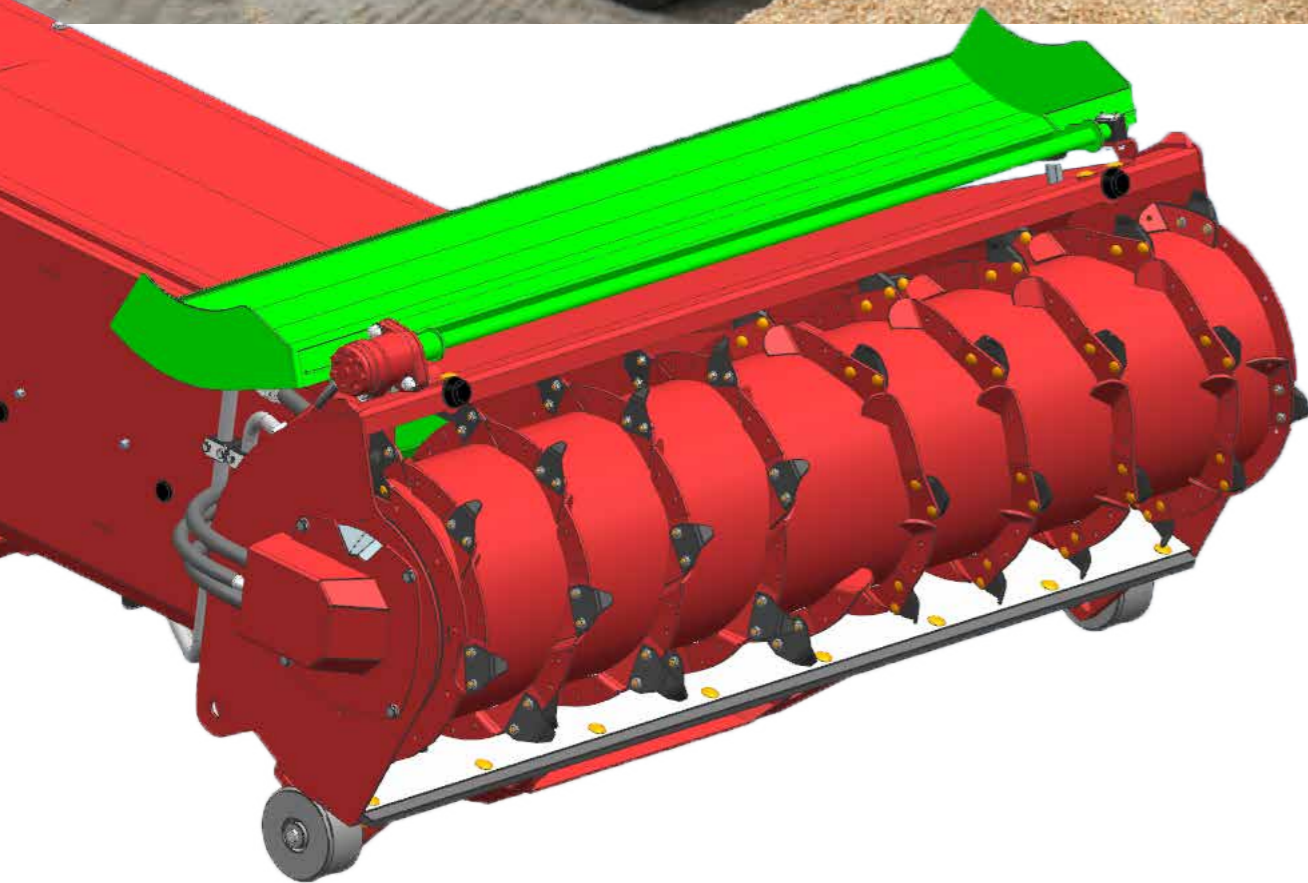

The pick-up milling cutter

- High-performance milling cutter equipped with 60 cranked knives for gentle picking-up and optimum cut surface shape
- Clean and fast picking-up of loose bulk materials and all kinds of silage
- Reversing option of conveyor duct, when the desired weight is reached to convey excess fodder back to the feed storage area

Top mixing performance & optimum discharge

The Vario mixing auger

– Variability and strength for any purpose

Due to the patented knife adjustment system, the Vario² mixing auger can be perfectly adapted to your specific conditions of use. The robust and low-maintenance angular gear ensures long service life even under unfavourable conditions.

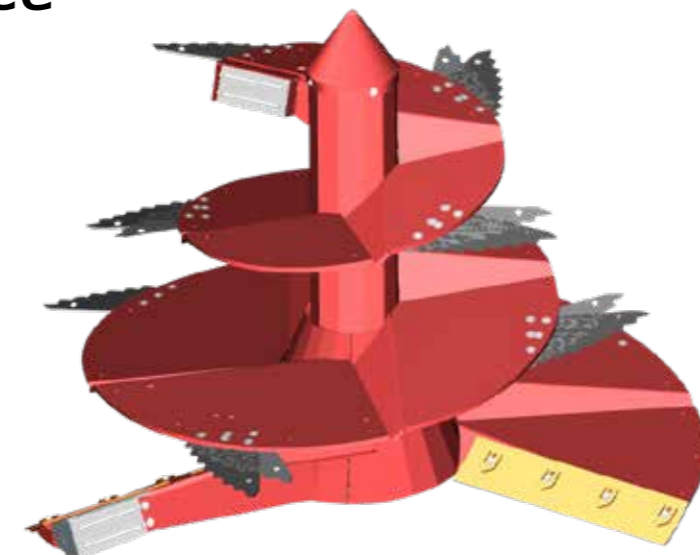

The Strautmann magnetic system

Each silage and any kind of purchased fodder might contain metallic foreign objects which might harm your dairy cattle. The Strautmann magnetic system (optional) is directly mounted at the mixing auger and very effective due to direct contact with the mixed fodder.



Result after 14 days of using our magnets (wedding ring as reference in the bottom right of the photo)



Discharge options

- Lateral front right and/or lateral rear left discharge gates
- With additional optional PVC discharge conveyor for discharge into elevated feed troughs

- Optional slope conveyor for minimum transport width despite fodder discharge at a distance from the machine
- In transport position, the slope conveyor is hydraulically pushed beneath the container



Safety & comfort

Driver's cabin



... when travelling and mixing



Axle & suspension

- Standard unsprung axles (15 km/h)
- With 25 km/h hydraulic suspension
- Rigid front axle, rear steering axle
- Particularly easy to manoeuvre
- Steering angle of 55°
- Differential lock

Feed hopper

- Optional extra
- Hydraulically powered
- For easy addition of e.g. mineral components even to already finished mixture



Mixer drive

- Hydrostatical with 2 speed levels

Counter-cutters

- Manual operation (hydraulic operation - from the driver seat - available as an optional extra)
- Enable the chopping of entire bales and optimise the mixing quality

Lighting & camera

- Lighting for road traffic according to STVZO (note of transl.: German Road Traffic Licensing Code)
- 2 work lights on the cabin
- 2 reversing lights (optional)
- 2 work lights at the discharge (optional)
- 1 LED work light for picking-up in the lower area
- Standard rear-view camera
- Container camera with work light (optional)



Technical modifications reserved

Strong performance – easy operation



4-cylinder engine

- Strong performance with low consumption
- Turbo diesel engine with Charge-air cooling (John Deere Emissions Level IV)
- 104 kW / 141 HP with 2000 rpm, 556 Nm with 1400 rpm



Operation

- Operation via joystick and toggle switches for secondary functions
- Easy-to-use display with an overview of the most important functions and actions
- With standard programmable weighing device, operation via touch display

Technical data

	Sherpa 120	Sherpa 140
Dimensions		
Length [m]	8,25	8,25
Height [m]	2,52	2,77
Width with one discharge door [m]	2,52	2,52
Width with two discharge doors [m]	2,62	2,62
Outer wheel width front [m]	2,31	2,31
Outer wheel width rear [m]	1,94	1,94
Diameter of loading drum [m]	0,61	0,61
Width of elevator arm [m]	0,58	0,58
Working width [m]	2,00	2,00
Removal height [m]	4,50	4,50
Tare weight		
Tare weight [kg]	10.200	10.300
Volume		
Usable mixing capacity [m ³]	12,0	14,0
Axle		
Wheel base [m]	3,86	3,86
Turn radius		
outer radius front [m]	5,26	5,20
outer radius rear [m]	5,73	5,73
inner radius [m]	1,43	1,43





www.strautmann.com

B. Strautmann & Söhne GmbH u. Co. KG



Bielefelder Straße 53
D-49196 Bad Laer
Tel.: +49(0)5424/802-0
Fax: +49(0)5424/802-76
info@strautmann.com